

(No Model.)

C. J. HARTLEY.
ELECTRIC ARC LAMP.

No. 512,880.

Patented Jan. 16, 1894.

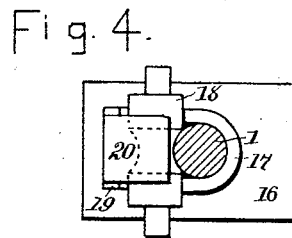
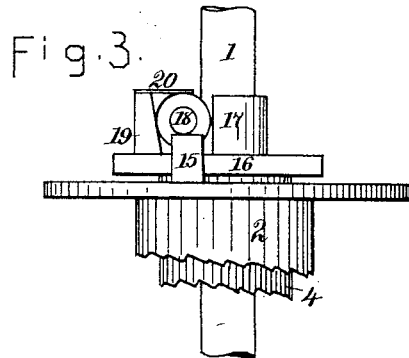
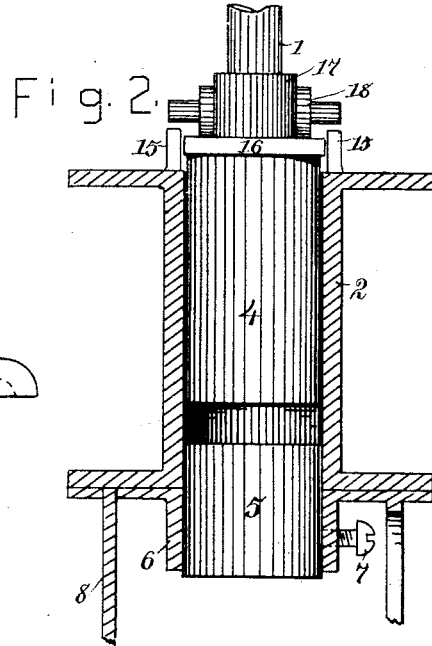
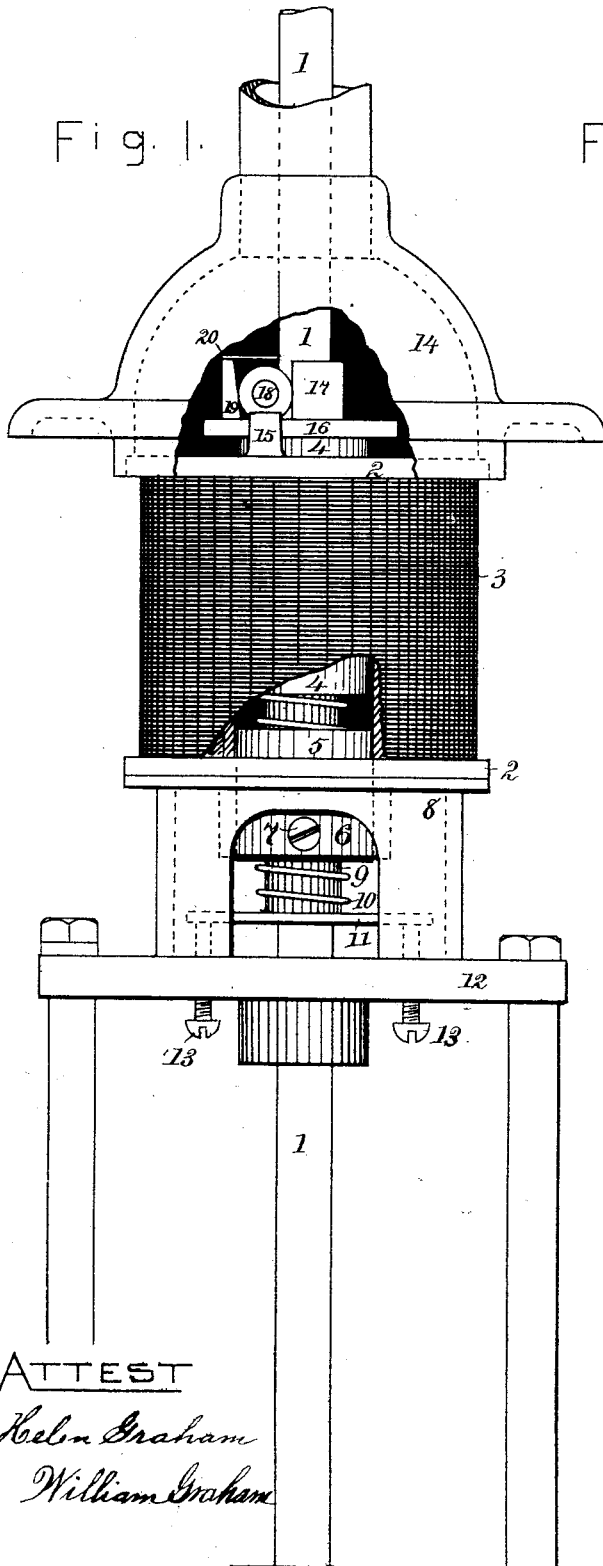

ATTEST

Helen Graham
William Graham

INVENTOR
C. J. HARTLEY.

by his attorney
L. P. Graham

UNITED STATES PATENT OFFICE

CHARLES J. HARTLEY, OF DECATUR, ILLINOIS, ASSIGNOR OF TWO-THIRDS
TO JOHN K. WARREN AND BRADFORD K. DURFEE, OF SAME PLACE.

ELECTRIC-ARC LAMP.

SPECIFICATION forming part of Letters Patent No. 512,880, dated January 16, 1894.

Application filed March 31, 1893. Serial No. 468,472. (No model.)

To all whom it may concern:

Be it known that I, CHARLES J. HARTLEY, of Decatur, in the county of Macon and State of Illinois, have invented certain new and useful Improvements in Arc Lamps, of which the following is a specification.

This invention is designed to improve the clutch mechanism of arc lamps, and to provide means for increasing or diminishing the effect of the derived circuit on the carbon-carrying core. It is embodied in the details of construction and combination of parts hereinafter set forth and claimed.

In the drawings forming part of this specification, Figure 1 is an elevation of so much of a lamp as is needed to illustrate my invention, parts being broken away to expose essential features. Fig. 2 is a section vertically through the center of the spool of the derived circuit, showing novel features and omitting all else. Fig. 3 is a side elevation of the clutch and adjuncts as they appear while releasing the carbon rod. Fig. 4 is a plan of the clutch.

1 is the carbon rod.

2 is the spool of the derived circuit wire.

4 is the carbon-carrying core on which the clutch is mounted.

5 is an adjustable core held in the lower end of the spool by means of a set screw, 7, extending through flange 6 of spool support 8. Plate 11 is adjustably supported by set screws 13 which extend through permanent plate 12, tube 9 extends upward from plate 11, and spring 10 encircles the tube and supports the core 4 yieldingly from the adjustable plate. Cap 14 is fitted on the upper end of the spool, and it protects the incased clutch mechanism. Plate 16, on the upper end of the core 4 has the upwardly extending semi-cylindrical bearing 17, conforming, in its inner surface, to the size and shape of the carbon rod; and it also has the bearing 19 on the opposite side of the carbon rod, the inner surface of which inclines upward and away from the carbon rod. Roller 18 lies between bearing 19 and carbon rod 1, and it is preferably grooved peripherally to conform to the shape of the carbon rod. It projects laterally beyond the sides of plate 16, and its diameter is such that it will press

closely against the carbon rod when at the bottom of the incline. The studs 15, on the upper end of the spool, are adapted to engage the ends of the roller, when the core is drawn downward by the derived circuit in coil 3, and such engagement causes the release of the carbon rod by raising the roller from its wedged position. The plate 20, on the upper end of bearing 19 holds the roller in operative position and also limits its upward motion and so increases its sensitiveness, or quickness of action. The adjustable core 5 becomes magnetized by the current of the derived circuit and tends to attract the movable core with a force inversely proportionate to the distance between the two. So when it is desired to increase the strength of the magnet the adjustable core is moved upward, or toward the moving core, and properly secured, and a reverse operation is performed to effect a contrary result. In making the adjustments it is necessary to avoid bringing the cores in actual contact. The use of the adjustable core enables the same lamp to be used under different circumstances and with different currents, and when the circumstances are determined and the core properly adjusted, no further attention is required until the circumstances change.

The clutch is simple, sensitive and secure, and the only essentials of its construction are that the inner surface of bearing 19 shall incline slightly backward and upward from a vertical line, that the diameter of the roller shall be sufficient to extend from the lower part of the bearing surface of the incline to the carbon rod, and that provision shall be made for raising the roller as the core 4 is drawn downward by the derived circuit.

Having thus described my invention, I claim as new and desire to secure by Letters Patent—

1. A clutch for the carbon rods of electric lamps, comprising an electrically controlled plate encompassing the rod, a bearing on the plate extending upward and inclining slightly away from the rod, a roller between the rod and the inclined bearing, and permanent stops adapted to raise the roller as the plate descends.

2. In clutches for electric lamps, the combination of a derived circuit spool, a core therefor, a carbon rod extending through the core, a plate, or head, on the core, a bearing
5 on the plate extending upward and inclining slightly away from the rod, a roller between the rod and the inclined bearing, and stops on the spool adapted to raise the roller as the core descends, substantially as set forth.
- 10 3. In clutches for electric lamps, the combination of the spool for the derived circuit, the core controlled thereby, the plate 16 on the core, the semi-cylindrical bearing 17 and the inclined bearing 19 extending upward
15 from the plate, the rod extending through bearing 17, the roller 18 between bearing 19 and the rod, the plate 20 to retain the roller in operative position, and the studs 15, on the upper head of the spool, adapted to engage
20 the ends of the roller, substantially as and for the purpose set forth.
4. An adjustable core in a derived circuit

spool or magnet adapted to act attractively on a movable or clutch carrying core.

5. In arc lamps, the combination of a solenoid on a non-magnetic spool, a clutch-carrying core controlled by the solenoid, a carbon rod extended through the clutch-carrying core and the spool, and a tubular core encircling the carbon rod and adjustable in the spool at
30 varying distances from the clutch carrying core substantially as set forth.

6. In arc lamps, the combination of spool 2 having the derived circuit wire 3, the clutch-carrying core 4 controlled by and movable in
35 the upper end of the spool, and the core 5 adjustable in the lower end of the spool by means of set screw 7, substantially as set forth.

In testimony whereof I sign my name in the presence of two subscribing witnesses.

CHARLES J. HARTLEY.

Attest:

E. M. HARTLEY,
WALTER C. KEELER.