

Jan. 23, 1962

W. M. WALDBAUER  
MOUNTING FOR LUMINAIRES

3,018,081

Filed March 27, 1958

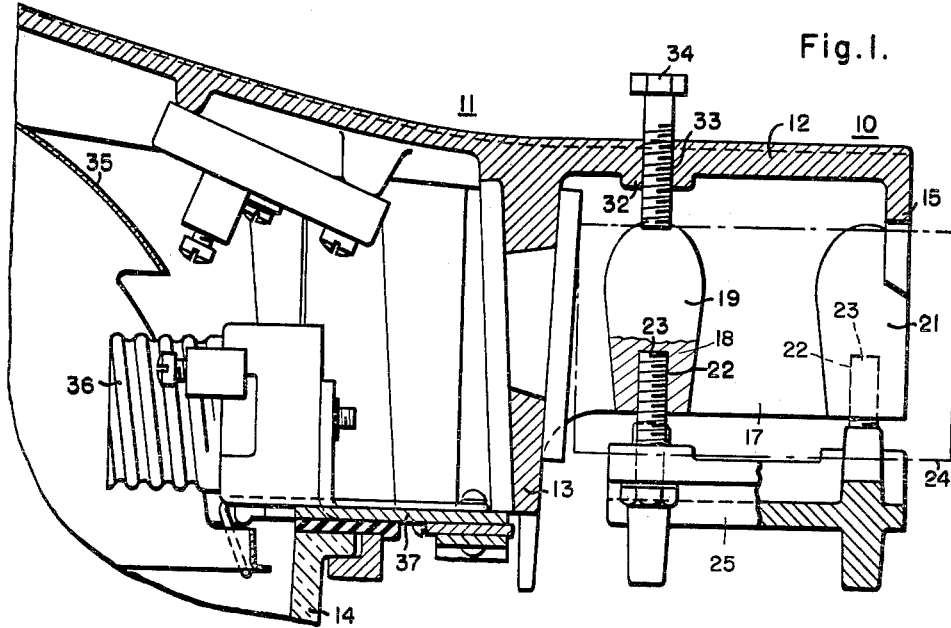

Fig. 1.

Fig. 2.

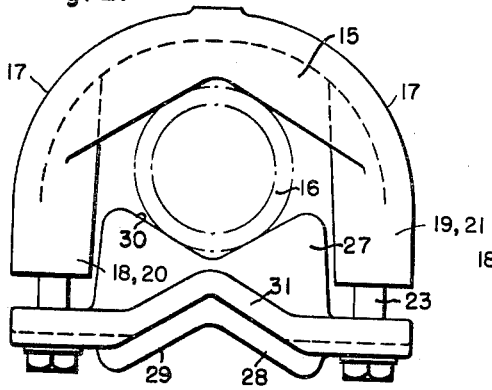

Fig. 3.

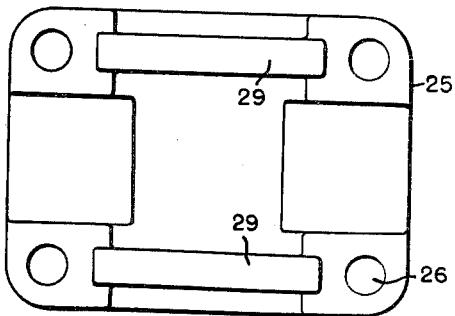
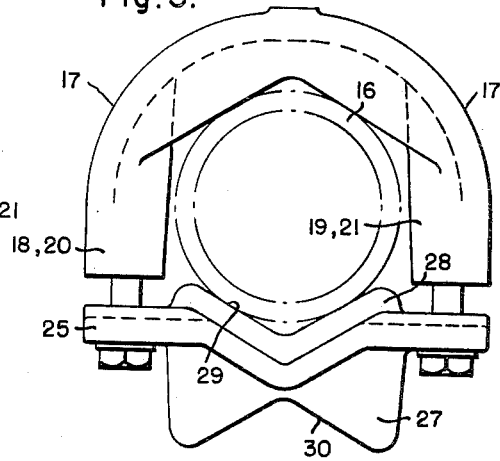

Fig. 4.

INVENTOR  
Walter M. Waldbauer  
BY  
*Arthur T. Stratton*  
ATTORNEY

1

3,018,081

**MOUNTING FOR LUMINAIRES**

Walter M. Waldbauer, North Olmsted, Ohio, assignor to Westinghouse Electric Corporation, East Pittsburgh, Pa., a corporation of Pennsylvania

Filed Mar. 27, 1958, Ser. No. 724,392

2 Claims. (Cl. 248—230)

The invention relates generally to slipfitters for mounting luminaires and more particularly to a slipfitter for mounting luminaires on brackets of different sizes.

The object of the invention is to provide a slipfitter for luminaires that can be mounted on brackets of different sizes by the reversal of a part.

It is also an object of the invention to provide in conjunction with a slipfitter, equipped with a reversible member to adapt it for mounting on brackets of different sizes, means cooperative for adjusting the slipfitter relative to the bracket to properly align the luminaire.

Other objects of the invention will in part be obvious and will in part appear hereinafter.

The invention, accordingly, comprises the features of construction, combination of elements, and arrangement of parts, which will be exemplified in the construction hereinafter set forth and the scope of application of which will be indicated in the claims.

For a fuller understanding of the nature and objects of the invention, reference should be had to the following detailed description taken in connection with the accompanying drawing, in which:

FIGURE 1 is a view in section showing details of the slipfitter structure and its application to a luminaire housing;

FIG. 2 is a view in end elevation of the slipfitter showing the clamping plate arranged to engage a bracket of one size;

FIG. 3 is a view in end elevation showing the slipfitter with its clamping members arranged to engage a bracket of larger size than the bracket illustrated in FIG. 2; and

FIG. 4 is a top plan view of the clamping plate provided in the slipfitter.

Referring now to the drawing, the slipfitter shown generally at 10 is cast integral with the housing of a luminaire, the base portion of which is shown generally at 11. While in this particular modification the supporting member or hood 12 of the slipfitter is cast integral with the housing of the luminaire, it is not necessary that these members be made in one piece. It would be satisfactory to bolt hood 12 to the housing or attach it rigidly in any other manner.

The slipfitter which will be described in detail hereinafter, actually comprises that portion of the structure illustrated in FIG. 1 which extends to the rear of the base member 13 which depends from the shell of the housing and cooperates in supporting the refractor 14 to completely enclose the light that will be housed by the luminaire. The luminaire housing may include a reflector 35 secured to the housing and socket 36 for a light source, mounted on a plate 37 also secured to the housing.

The supporting member or hood 12 is provided with depending side walls 17 spaced far enough apart to enable the fitting of them over a bracket 16. At the pole end of the hood 12 there is another depending wall or web 15 which extends between the walls 17. This depending end wall or clamping member 15, as best shown in FIGS. 2 and 3, has a substantially V-shaped lower edge which, as will be described hereinafter, constitutes one of the members of a clamp for gripping the bracket 16. Since the slipfitter is intended for use on brackets 16 of different sizes, the walls 17 will be so spaced that they will fit over the largest bracket 16 for which the slipfitter is intended.

In this particular embodiment of the invention, since the hood of the slipfitter may be cast, four bosses 18 to 21

2

inclusive may be cast integral with the walls 17 and at the corners of the hood 12. (Boss 18, shown in FIG. 1, is partially sectioned and broken away.) While in this instance the bosses 18 to 21 inclusive are made integral to the hood, it will readily be appreciated that they may be separate units and applied in any other well-known manner such as by bolting or riveting.

The depending bosses 18 to 21 are provided for supporting a clamping member to be described hereinafter. Therefore, each of the bosses 18 to 21 has a tapped opening 22 provided therein for receiving screwbolts 23. The tapped openings 22 will extend far enough into the bosses to assure that the screwbolts 23 make a good connection. Reference to FIG. 3 shows that the bosses 18 to 21 also will limit the lateral movement of the slipfitter on the bracket 16.

The brackets 16 most commonly provided for mounting luminaires are usually lengths of pipe fastened in a street-lighting pole, not shown. However, it is to be understood that other types of brackets may be employed provided about 6" of the street end is rounded to adapt it to fit the slipfitter. It is considered sufficient to state that the right hand end of the pipe sections 16 as viewed in FIG. 1 and which is designated by the legend 24 is the pole end. These pipe sections are generally lengths of pipe 1 1/4 inches and 2 inches in diameter. The size will be determined by the load the bracket will be required to carry.

In order to clamp the slipfitter shown generally at 10 to the brackets 16, a plate 25 is provided. This plate 25 is best shown in FIG. 4 and in size is substantially the same as the area defined by the depending walls 17 and the bosses 18 to 21 inclusive. The plate 25 will be provided with four openings 26 located at the corners and so disposed that they will align with the openings 22 provided in the bosses 18 to 21 inclusive. The openings 26 will be made the size required to receive the screwbolts 23 provided for attaching it to the bosses 18 to 21 inclusive.

A convenient method for making the plate 25 is by casting. It is usual to make luminaire housings and the slipfitters of aluminum which may be readily cast to provide all the required members with great accuracy. However, the present invention does not require that the members be made from aluminum castings. The whole structure might be machined or made in small parts and then assembled to meet the requirements of the particular structure. No matter how the housing and plate 25 are made, the members already described and to be described hereinafter will have to be provided. Jaw members 27 and 28 are provided at opposite ends extending on opposite sides of the plate 25 and may be cast integral with it. As best shown in FIGS. 2 and 3, the jaw members 27 and 28 have specially shaped edges or faces.

Referring now to FIGS. 2 and 3, it will be observed that the brackets 16 are of different sizes. The brackets 16 shown in FIG. 2 is smaller in diameter than the bracket illustrated in FIG. 3. The edges or faces 29 and 30 of the jaw members 27 and 28 shown in FIGS. 2 and 3 are substantially V-shaped simulating the lower edges of the wall or web 15. The slope of the sections of the face 30 will be somewhat different from the slope of the sections of the face 29 in order to adapt them for engaging pipes of different sizes. The face 30 of the jaw member 27 will be designed or sloped to grip the smaller bracket 16 while the face 29 of the jaw member 28 will be shaped to engage a larger pipe or bracket 16.

Therefore, in mounting this slipfitter shown generally at 10 on a bracket 16, it can be adapted to two different sizes of bracket 16 by reversing the plate 25. It will be noted that the central portion of plate 25 is bowed upwardly as shown on FIG. 2 or downwardly as shown on FIG. 3. This bowed section 31 is substantially V-shaped and facilitates the making of the jaw members 27 and 28

3

of the right size and shape to engage brackets 16 of different sizes. It also provides that the bolting flange 25 will be in substantially the same vertical location to the hood 10. Thus, the length of screwbolts 23 need not be varied.

Referring now to FIG. 2, it will be noted that the part of the jaw member 27 extending on the same side of the plate 25 as the V-shaped middle section 31 is much higher relative to the plate than the opposite sections of the jaw members 28. These high sections of the jaw members extend between the depending walls 17 of the hood member 12, and therefore, must be made of a size to enable their fitting into the hood.

In order to provide for properly aligning the luminaire on the bracket 16, a boss 32 is provided on the supporting members 12. A threaded opening 33 extends through the support member 12 and the boss 32. An adjustable screwbolt 34 extends through the threaded opening 33.

In mounting the slipfitter on a bracket 16, when the support member or hood 12 is in position, the plate 25 will be applied to the bottom by means of the screwbolts 23. If the bracket 16 is a pipe length  $1\frac{1}{4}$  inches in diameter, then the V-shaped jaw section 31 will be disposed with the apex upwardly presenting the jaw faces 30 designed for engaging the pipe of smaller diameter as shown in FIG. 2. If the bracket 16 is two inches in diameter, then the plate 25 will be reversed as shown in FIG. 3.

The screwbolts 23 at the pole end of the slipfitter will be tightened first to grip the bracket 16. Then the adjusting screwbolt 34 will be manipulated or adjusted to align the housing with the bracket to give the luminaire the proper inclination to the surface to be illuminated. Then the screwbolts 23 at the opposite end of the plate will be tightened. If the luminaire does not have the exact alignment desired, the screwbolts 23 and 34 will be adjusted until the luminaire is set at the proper angle to the surface to be illuminated. When this has been effected, all of the screwbolts 23 will be tightened firmly setting the slipfitter on the bracket 16.

In some instances, it may be desirable to have the faces 29 and 30 and the depending face of the jaw member 15 gnarled to improve the gripping characteristics of the slipfitter. However, this is not essential.

Since certain changes may be made in the above construction, and different embodiments of the invention could be made without departing from the scope thereof, it is intended that all matter contained in the above description or shown in the accompanying drawing shall be interpreted as illustrative and not in a limiting sense.

I claim as my invention:

1. In a luminaire housing, a slipfitter at one side for

4

mounting said housing on a bracket, said slipfitter including a hood having spaced depending walls disposed to carry the housing, a clamping member extending between the depending walls of the hood, bosses formed integrally with the depending walls and having threaded openings extending upwardly from their lower ends, a clamping plate having openings therethrough aligning with the openings in the bosses, a plurality of spaced jaws carried by the clamping plate and extending to opposite sides, the spaced jaws on the opposite sides of the clamping plate being adapted to engage brackets of different sizes, screw bolts fitting through the openings in the clamping plate and engaged in the threaded openings provided in the bosses for drawing the desired jaws on the clamping plate into cooperative relationship with the clamping member provided on the hood for setting the luminaire housing in position on the bracket.

2. In a luminaire housing, a slipfitter for mounting said housing on a bracket, said slipfitter including a hood having a top portion and spaced depending side walls, a depending end wall on said hood which is of an inverted V-shape so as to form a clamping member, a pair of spaced bosses formed integrally with each depending side wall and having threaded openings extending upwardly from their lower ends, and adjustable means disposed in said hood, a clamping plate having openings therethrough in registration with the openings in said bosses, a pair of cooperating spaced jaws carried by said plate on one side thereof having dimensions so as to be able to engage brackets of one size, a pair of cooperating spaced jaws carried by said plate on the opposite side thereof having dimensions so as to be able to engage brackets of another size, screw bolts fitting through the openings in said clamping plate and engaged in the threaded openings provided in the bosses for drawing either one of the pairs of jaws on the clamping plate into cooperative relationship with the jaw provided on the hood and for cooperating with said adjustable means for setting the luminaire housing in different predetermined positions to dispose it at the proper angle to the surface to be illuminated.

#### References Cited in the file of this patent

##### UNITED STATES PATENTS

999,998	Hine	Aug. 8, 1911
2,337,824	Kraut	Dec. 28, 1943
2,733,034	Tormo	Jan. 31, 1956
2,778,929	Loehr	Jan. 22, 1957
2,848,182	Wildberg	Aug. 19, 1958

##### FOREIGN PATENTS

678,959	France	Jan. 2, 1930
---------	--------	--------------